

# HADES X



## User Manual

KEEP THIS MANUAL FOR FUTURE NEEDS

[www.moxlite.com](http://www.moxlite.com)

# USER MANUAL

Thank you for purchasing our products, please take some minutes to read this manual before operating any of these laser projectors!

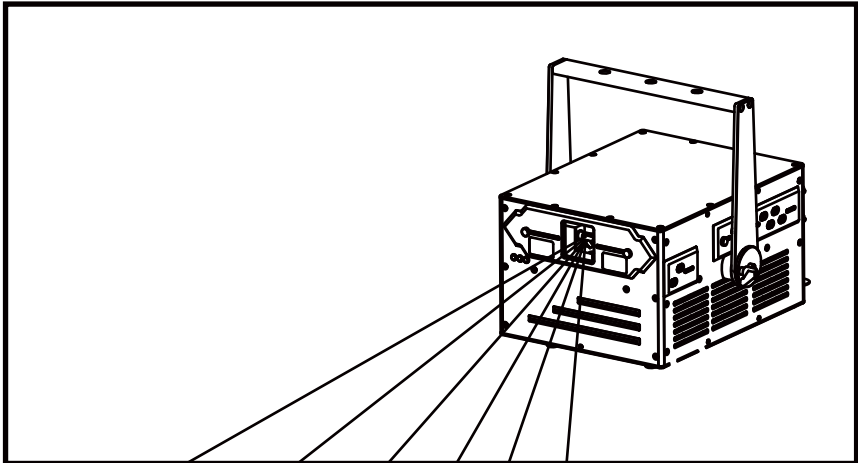

PR3000A-RGB	PR9000 - RGB	CF20000-RGB	WP35000-RGB
PR4000A-RGB	PR10000-RGB	CF24000-RGB	WP37000-RGB
PR5000A-RGB	PR13000-RGB	CF30000-RGB	WP45000-RGB
PR5500A-RGB	PR14000-RGB	CF33000-RGB	WP48000-RGB
PR6000A-RGB			
PR8000A-RGB	PT6000-EGB	PT8000-RGB	

Notice  
AVOID EYE OR SKIN EXPOSURE TO  
DIRECT OR SCATTERED LIGHT  
CLASS 4 LASER PRODUCT

Manufactured/ Certified by  
Shenzhen Optlaser Technologies Co.,Ltd  
[www.optlaser.com](http://www.optlaser.com)



# CONTENT

<b>INTRODUCTION</b>	- - - - -	01
<b>SAFETY NOTES</b>	- - - - -	02-03
<b>LABELLING REFERENCE</b>	- - - - -	04-05
<b>PROPER USAGE</b>	- - - - -	06
<b>OPERATIONS</b>	- - - - -	07-08
Explanation of SFS		
<b>Emergency Stop Box</b>	- - - - -	09-10
<b>LCD Display Setting introductions</b>	- - - - -	11-15
<b>PR5 SERIES</b>	- - - - -	16-18
Standard Verisons(without FB4 built-in)		
<b>PT6 SERIES</b>	- - - - -	19-21
Standard Verisons(without FB4 built-in)		
<b>PR10 SERIES</b>	- - - - -	22-24
Standard Verisons(without FB4 built-in)		
<b>CF20 SERIES</b>	- - - - -	25
Standard Verisons(without FB4 built-in)		
<b>CF30 SERIES</b>	- - - - -	26
Standard Verisons(without FB4 built-in)		
<b>INTRODUCTIONS OF CF20   CF30</b>	- - - - -	27
<b>Specifications OF CF20   CF30</b>	- - - - -	28
<b>WP35 SERIES</b>	- - - - -	29-31
Standard Verisons(without FB4 built-in)		
<b>WP45 SERIES</b>	- - - - -	32-34
Standard Verisons(without FB4 built-in)		
<b>DMX Charts</b>	- - - - -	35-38
<b>DMX and ArtNet file structure</b>	- - - - -	39
<b>ZLDA file structure</b>	- - - - -	40
<b>MAINTENANCE AND SERVICE</b>	- - - - -	41-44
<b>SERVICE</b>	- - - - -	45-46

## INTRODUCTION

Thank you for purchasing our products. To optimize the performance of your laser, please read these operating instructions carefully and familiarize yourself with the basic operations of this system. These instructions contain important safety information regarding the use and maintenance of this system as well. Please keep this manual with the unit, for future reference. If you sell this product to another user, be sure that they also receive this document.

### Notice

- We are constantly striving to improve the quality of our products. As such, the content of this manual may be changed without notice.
- We have tried our best to guarantee the accuracy of this manual. If you have any questions or find any errors, please contact us directly to help correct this.

## PACKING LIST

Name	Qty(pcs)
<b>LASER projector</b>	<b>1</b>
<b>AC power cord</b>	<b>1</b>
<b>Safety Keys</b>	<b>2</b>
<b>Power output connector</b>	<b>1</b>
<b>Remote Interlock connector</b>	<b>2</b>
<b>Allen key</b>	<b>1</b>

### Applicable Accessories

<b>E-stop box</b>	<b>1</b>
<b>CAT5/6 cable</b>	<b>1*1.5m</b>
<b>ILDA cable</b>	<b>1*1.5m</b>
<b>DMX cable</b>	<b>1*1.5m</b>
<b>Safety cable</b>	<b>1*1.5m</b>

## UNPACKING INSTRUCTIONS

Open the package and carefully unpack everything inside.

Ensure all parts are present and in good condition.

Do not use any equipment that appears to be damaged.

If any parts are missing or damaged then please immediately notify your carrier or local distributor.

## GENERAL INFORMATION

The following chapters explain important information about lasers in general, basic laser safety and some tips about

how to use this device correctly. Please read this information as it contains critical information you must be aware of, prior to using these system.

## SAFETY NOTES

**WARNING!** These projectors are Class 4 laser products. It must never be used for audience-scanning applications. The output beam of the projector must always be at least 3 meters above the floor in the audience. See the Operating Instructions section for further information.

Please read the following notes carefully! They include important safety information about the installation, usage, and maintenance of this product.

- Keep this User Manual for future consultation. If you sell this product to another user, be sure that they also receive this document.
- Always make sure that the voltage of the outlet to which you are connecting this product is within the range stated on the decal or rear panel of the product.
- This product is not designed for use outdoors in adverse weather conditions. To prevent risk of fire or shock, do not expose this product to rain or moisture.
- Always disconnect this product from the power source before cleaning it or replacing the fuse.
- Make sure to replace the fuse with another of the same type and rating.
- If mounting it overhead, always secure this product to a fastening device using a safety chain or cable.  
\*In the event of a serious operating problem, stop using the projector immediately. Never try to repair the unit except in a controlled environment under trained supervision. Repairs carried out by unskilled people can lead to damage or malfunction of the unit, as well as exposure to dangerous laser light.
- Never connect this product to a dimmer pack.
- Make sure the power cord is not crimped or damaged.
- Never disconnect the power cord by pulling or tugging on the cord.
- Never carry a product from the power cord or any moving part. Always use the hanging/mounting bracket or the handles.
- Always avoid eye or skin exposure to direct or scattered light from this product.
- Lasers can be hazardous and have unique safety considerations. Permanent eye injury and blindness is possible if lasers are used incorrectly. Pay close attention to each safety REMARK and WARNING statement in this user manual. Read all instructions carefully BEFORE operating this device.
- Never intentionally expose yourself or others to direct laser light.
- This laser product can potentially cause instant eye injury or blindness if laser light directly strikes the eyes.
- It is illegal and dangerous to shine this laser into audience areas, where the audience or other personnel could get direct laser beams or bright reflections into their eyes.
- It is a US Federal offense to shine any laser at aircraft.
- No service allowed by customer. There are no user serviceable parts inside the unit. Do not attempt any repairs yourself.
- Service is only to be handled by the factory or authorized factory trained technicians.
- Product is not to be modified by the customer.
- Caution – use of controls or adjustments or performance of procedures other than those specified herein may result in hazardous radiation exposure.



## LASER AND SAFETY NOTES

### STOP AND READ ALL THE LASER SAFETY NOTES BELOW

Laser Light is different from any other light sources with which you may be familiar. The light from this product can cause eye and skin injury if not set up and used properly. Laser light is thousands of times more concentrated than light from any other kind of light source. This concentration of light can cause instant eye injuries, primarily by burning the retina (the light sensitive portion at the back of the eye). Even if you cannot feel “heat” from a laser beam, it can still potentially injure or blind you or your audience. Even very small amounts of laser light are potentially hazardous even at long distances. Laser eye injuries can happen quicker than you can blink. It is incorrect to think that because these laser entertainment products use high speed scanned laser beams, that an individual laser beam is safe for eye exposure. It is also incorrect to assume that because the laser light is moving, it is safe. This is not true.

Since eye injuries can occur instantly, it is critical to prevent the possibility of any direct eye exposure. It is not legal to aim this laser projector into areas where people can be exposed. This is true even if it is aimed below people’s faces, such as on a dance floor.

- Do not operate the laser without first reading and understanding all safety and technical data in this manual.
- Always set up and install all laser effects so that all laser light is at least 3 meters (9.8 feet) above the floor on which people can stand. See the “Proper Usage” section later in this manual.
- After set up, and prior to public use, test the laser to ensure proper function. Do not use if any defect is detected.
- Laser Light - Avoid Eye or Skin Exposure to Direct or Scattered Light.
- Do not point lasers at people or animals.
- Never look into the laser aperture or laser beams.
- Do not point lasers in areas where people can potentially be exposed, such as uncontrolled balconies, etc.
- Do not point lasers at highly reflective surfaces, such as windows, mirrors and shiny metal objects. Even laser reflections can be hazardous.
- Never point a laser at aircraft, as this is a US Federal offense.
- Never point un-terminated laser beams into the sky.
- Do not expose the output optic (aperture) to cleaning chemicals.
- Do not use the laser if the housing is damaged, open, or if the optics appear damaged in any way.
- Never leave this device running unattended.
- In the United States, this laser product may not be purchased, sold, rented, leased or loaned for use unless the recipient possesses a valid Class 4 laser light show variance from the US FDA CDRH.
- This product must always be operated by a skilled and well-trained operator who is familiar with the data included in this manual. Note that use of this projector in the United States also requires a valid Class 4 laser light show variance from the CDRH as stated above.
- The legal requirements for using laser entertainment products vary from country to country. The user is responsible for the legal requirements at the location/country of use.
- Always use appropriate lighting safety cables when hanging this projector overhead.



See the following reproductions of the product labels. All these labels must be intact and legible prior to be used on the projector.





Hazard warning symbol

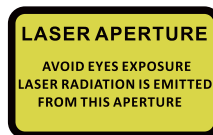

Aperture label



**CE RoHS**  

Note:  
Read user manual before use | Operation by qualified personnel only  
Never point laser beam at people | Never look into laser beam directly  
Any after sales services request, please contact your local authorized dealer or the direct seller for help.

Laser Wavelength(nm):  
R  637  638  
G  520  532  
B  445  450  465

Total Power: \_\_\_\_\_W  
Voltage AC:  100-120V  200-240V 100-240V 50-60Hz  
Consumption: \_\_\_\_\_W  
Year: \_\_\_\_\_

**LASER RADIATION**  
AVOID DIRECT EYE EXPOSURE  
CLASS 4 LASER PRODUCT  
DIN EN60825-1: 2015-07

**CAUTION OF RADIATION**  
IF COVER IS MOVED

**NEVER AIM AT AIRCRAFT, IT IS UNSAFE AND ILLEGAL**  
Complies with IEC 60825-1 and 21 CFR 1040.10

### PROPER USAGE

This product is for overhead mounting only. For safety purposes, this projector should be mounted on steady elevated platforms or sturdy overhead supports using suitable hanging clamps. In all cases, you must use safety cables.

International laser safety regulations require that laser products must be operated in the fashion illustrated below, with a minimum of 3 meters (9.8 ft.) of vertical separation between the floor and the lowest laser light vertically. Additionally, 2.5 meters of horizontal separation is required between laser light and audience or other public spaces.

The audience area can be passively protected by sliding the aperture cover plate upwards and fixing it in proper position by the two thumb screws.

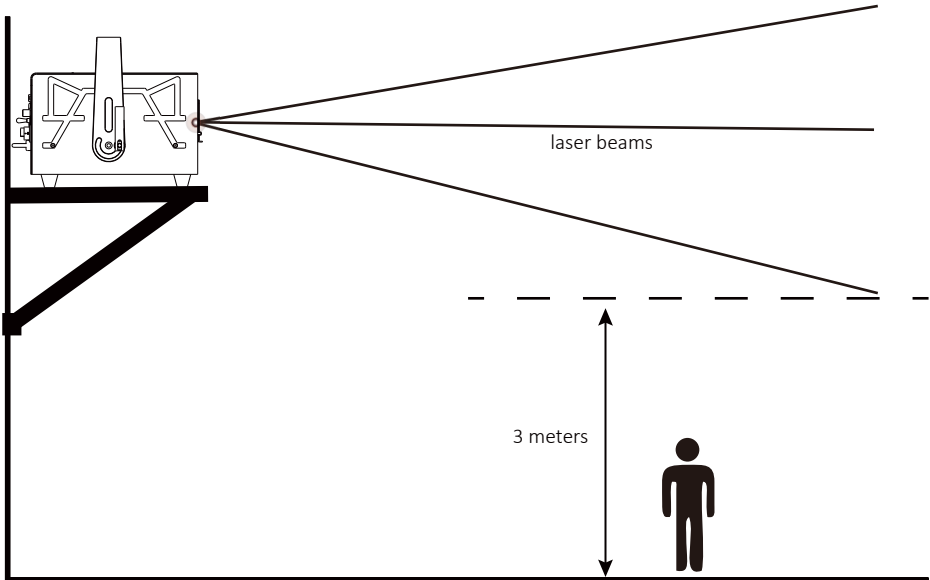

### RIGGING

- Be sure that the structure onto which you are mounting this product can support its weight.
- Mount the product securely. You can do this with a screw, a nut, and a bolt. You may also use a mounting clamp if rigging this product onto a truss. The U-shaped support bracket has three mounting holes which may be used to secure the clamps to the projector.
- Always consider ease of access to the unit before deciding on a location for this product
- When mounting this product overhead, always use a safety cable to lock the projector thru the safety ring(s) that attached on the back panel.

Stainless steel safety cable





## OPERATIONS

Our laser systems come with semiconductor diode-based only laser sources and all sources have beam corrections, thus have great beam show with analog FULL colors modulation.

The PR SERIES units can be controlled over ILDA and have a built-in memory with preset patterns, also with TF-card slot for freely programs export onto it, that can be easily triggered by DMX. They can also be operated in automatic.

The laser projector provides a master-slave-mode. Show lasers of the same series (slave projectors), connected via DMX to a main projector (master projector) project the same patterns like the master projector.

This Series will be applicable for clubs, bars, and those Small/medium venues or theater events, parties, business activities, large venues etc.

The projector(s) is /(are) not supplied with the standard "E-Stop Box" and the "Remote Interlock bypass connector". Instead, these accessories will be supplied in the purchase according to request.

The "E-stop Box" generally comes with a 1.5 m long CAT5 cable unless special requests are made during purchasing communications.

If user doesn't need the additional "E-Stop box" to handle the laser projector, then the included "RJ45 interlock connector" should be inserted into the rear plate of the projector's INTERLOCK position (with silkscreen marking), only in this way user will be able to enable the laser outputs during operations.

## Explanation of SFS

Scan-fail safety button, a protection feature for preventing the straight single laser beam from outputting when if the scanner set is malfunctioning or the laser cue's size is intentionally set to too small scale such as 10.

And this safety/protection can only be activated when the button is pressed down.

### When Operation is without the E-stop box!



#### Several steps to start up the laser projector(s)

1. Use the included power cord to connect the laser device to a proper power outlet(AC100-240V, 50/60Hz)
2. Use one of the included keys( 2 sets included in the package, either one of them will work) to insert into the key-chassis and switch to the "ON" position
3. Use one of the the included INTERLOCK connectors to insert into the INTERLOCK position on the backplate of the device. (2 x RJ45 connectors(well made) included in the package)

**Remark:** There are 2 positions for INTERLOCK on the backplate of the devices  $\geq 10W$

herein, either one of the positions will work(one only position needs to be with INTERLOCK connector inserted if the laser projector will be used alone.

Both INTERLOCK positions will work if user wants to daisy chain 2 or more laser projectors through **E-stop box**.

4. Turn on the power switch from  to , then the laser device will start output laser light. 

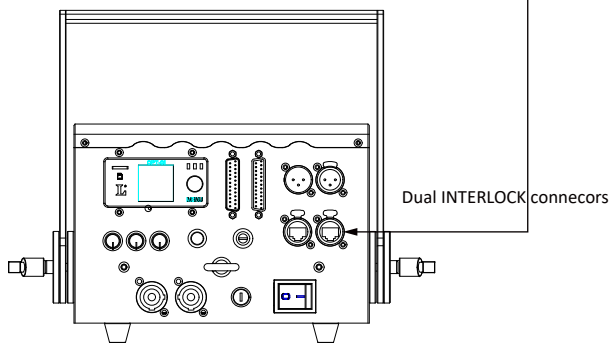

# Emergency Stop Box



## Schematic of the E-stop Box

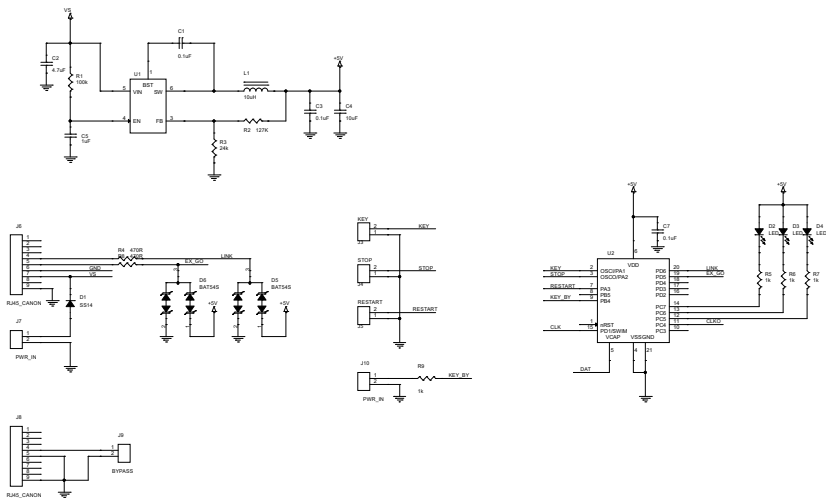

RS	RevisedControlBox09.kicad	
AL	Microcontroller	1.0
DL	10/20/2017 14:14	

## When Operation is with the E-stop box!



**A:** Use the supplied Neutrik powercon cable to connect the laser projector to a AC main power supply by using the input connector. Insert the safety keys(remain in the Off position).



**B:** To control the system by using an external signal e.g. ILDA or Ethernet(if FB4 built-in), plug the corresponding cable to the input connector at the back of the laser system.



**C:** Connect the E-stop box to the socket marked as INTERLOCK IN with a supplied CAT5/6 cable.



Remote interlock Bypass connector.



**D:** Insert the Remote interlock Bypass connector to the E-stop box and turn the key to on to disable the INTERLOCK (the US regulations).



**E:** Release the E-stop button by anti-clockwise rotation, and the button will be pulled upwards.



**F:** Press down the START button on the E-stop box. Turn the keys and the power switch at the back of the laser system to the ON positions.



**G:** After the emission delay period of about 10-14s, the laser system is ready to start output laser emission by Enabling output thru laser software.

(Over these steps, the laser system is controlled by ILDA signal, in which way, make sure that the ILDA cable is well connected between the projector and the ILDA DAC controller which has to be well connected to the PC as well).

**In any emergency, press down the STOP button to disable laser output!**

### LCD Display Setting introductions

#### Indicators

a. Power supply and TF Card status indication:



OFF	Not powered
Slow flash	No TF Card
Always on	With TF Card

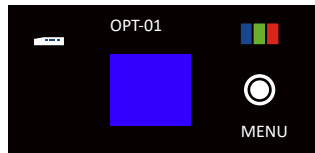

b. DMX status



OFF	Without DMX daughterboard   Abnormal
Slow flash	DMX daughterboard loaded , but no DMX Signal
Always on	Normal DMX communication

c. Laser Output status



OFF	No output
Always on	Normal output

#### Note:

All the contents listed on the LCD display can be freely changed to the preferable status. The most important step is to “double-click” the menu knob to SAVE the preferred status when all selections/settings get done. (The other settings should be operated step by step as DMX setting reference as the guidance following)

#### MENU Content | Items



For instance, ZLDA display mode is chosen from “Operation Mode”



For instance, DMX512 display mode is chosen from “Operation Mode”

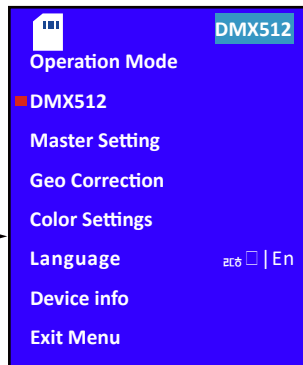
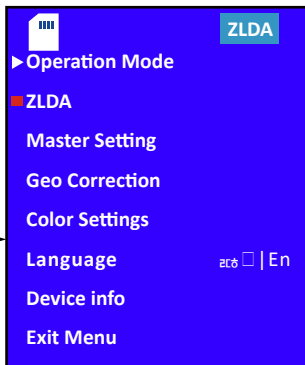
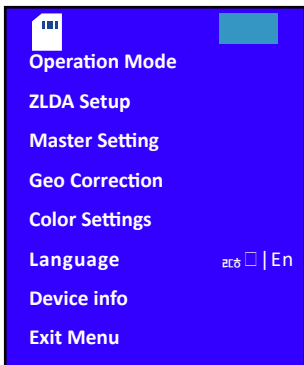

**Remark area**(the actual screen is without this colored background)

The real-time display mode status will be shown in this area, it can be any mode under the content Operation Mode such as ZILDA or DMX512, etc.

## MENU Descriptions

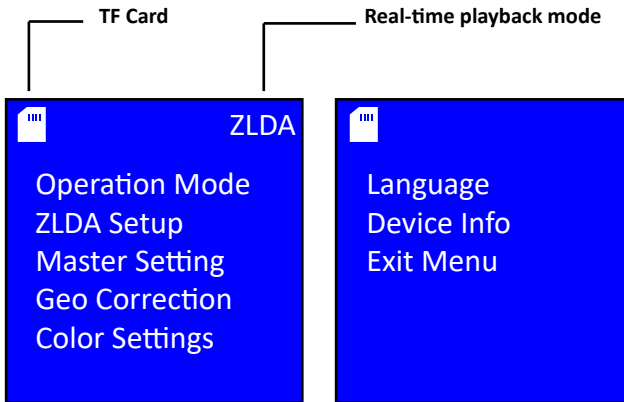

## The Overall menu's content

Menu Item	Description
Operation Mode	Select the playback method, including [ DMX512 ], [ ILDA ], [ ZLDA ], [ TEST ] and [ DAC ] and other playback mode
ZLDA Setup	Settings corresponding to the selected playback mode
Master Setting	Basic settings of the system
Geo Correction	Orientation parameter settings   Geo correction
Color Settings	Color parameter settings
Language	Chinese   Simplified Chinese      En   English
Device info	Device version and other information
Exit Menu	Save settings and turn off backlight

## Master Setting

Menu Item	Description	default value
Scan Rate	The number of points of laser output per second, range 5~40K	20
Color Shift	The number of points of the color lag coordinate, range 0~15 points	0
Rescan	After the playback source is disconnected, the duration before the program is turned off, unit millisecond, range 100~999ms	999
Each Play	The minimum playing time of each program, in seconds, range 1~20s	2
Turn Off Time	After there is no operation on the interface, the screen-off time, in seconds, ranges from 5 to 60s , 60s means the screen is always on	30
Animate Mode	1 —display as per points 2 —display as per frames	1
Animate Rate	This parameter is valid when display as per points is selected. 1 is full speed, 2 is 1/2 speed, 3 is 1/3 speed	1
Target FPS	If you choose to play by frame, this parameter is valid. The number of frames of the program played per second, frame range 1~40	10
Exit	Exit the current menu and return to the previous menu	

## Selections of Operation Mode

Menu Item	Description	default value
DMX512	DMX512 Control mode, program data comes from TF card, corresponding to the dmx\ directory ZLDA format file.	×
ILDA Play	ILDA Play, program data comes from TF ILDA under the ilda\ directory in the card format file.	×
ZLDA Play	ZLDA Play, program data comes from TF ZLDA under the zlda\ directory in the card format file.	×
TEST Play	TEST Play, program data comes from TF ZLDA in the test\ directory in the card format file.	×
Exit	Exit the current menu and return to the previous menu.	

## Geo Correction

Geo Correction	
Master Size	100
X Scale	100
Y Scale	100
X Shear	0
Y Shear	0
Z angle	0
X Position	0
Y Position	0
X Invert	✗
Y Invert	✗
XY Swap	✗
Exit	

Menu Item	Description	default value
Master Size	0~100%	50
X Scale	0~100%	100
Y Scale	0~100%	100
X Shear	- 100~100%	0
Y Shear	- 100~100%	0
Z Angle	0~359	0
X Position	- 100~100%	0
Y Position	- 100~100%	0
X Invert	0 1 0-Positive, 1-Reverse	×
Y Invert	0 1 0-Positive, 1-Reverse	×
XY Swap	0 1	×
Exit	Exit the current menu and return to the previous menu	

## ZLDA Setup

### Sub-menu

Play Mode
File Index
End Action
Exit

Menu Item	Description	default value
Play mode	[Cue] Means only one laser cue will be displayed in loop, corresponding to ZLDA in the ilda\cue\ directory format file . [List] Presents the playlist file, corresponding to ZLDA in the ilda\list\001~999\ directory grid format file. [None] No output	single
File Index	The number of files currently being played, from 001 to 999 . Select [Single] for playback mode, which means 001.zld~999.zld in the zlda\cue\ directory Select [List] for the playback mode, which means the files in the 001~999\ directory under the zlda\list\ directory.	001
End Action	[Loop] After the program reaches the end, it will start playing from the beginning. [Stop] After the program reaches the end, turn off the laser output.	cycle
Exit	Exit the current menu and return to the previous menu	

## LCD Wiring guidelines



1 2

1 2 3 4 5 6 7

### Power connections

Pin	name	Voltage
1	GND	0
2	VCC	+7V ~ +24V

### DMX input

Pin	name	Voltage
1	GND	0
2	DMX RX	— —
3	DMX Tx	— —
4	I2C SCL	— —
5	I2C SDA	— —
6	I2C INT	— —
7	VCC	3.3V



1 2 3 4 5 6 7 8 9 10 11 12

1 2 3 4 5 6

1 2 3 4 5 6 7 8

### ILDA Input

Pin	name	Voltage
1	GND	0
2	HAS	ground
3	EN	ground
4	GND	0
5	B IN	0 ~ +5V
6	G IN	0 ~ +5V
7	R IN	0 ~ +5V
8	GND	0
9	YIN-	-5V ~ +5V
10	YIN+	-5V ~ +5V
11	XIN-	-5V ~ +5V
12	XIN+	-5V ~ +5V

### RGB output

Pin	name	Voltage
1	Red	0 ~ +5V
2	Green	0 ~ +5V
3	Blue	0 ~ +5V
4	Deep Blue	0 ~ +5V
5	Yellow	0 ~ +5V
6	Cyan	0 ~ +5V
7	Shutter	— —
8	GND	0

### GS Output

Pin	name	Voltage
1	Y+	-5V ~ +5V
2	Y-	-5V ~ +5V
3	GND	0
4	GND	0
5	X-	-5V ~ +5V
6	X+	-5V ~ +5V

**PR5 SERIES**

Standard Versions(without FB4 built-in)

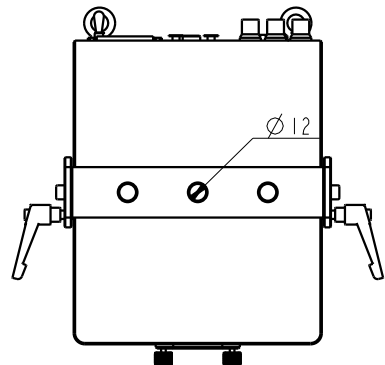
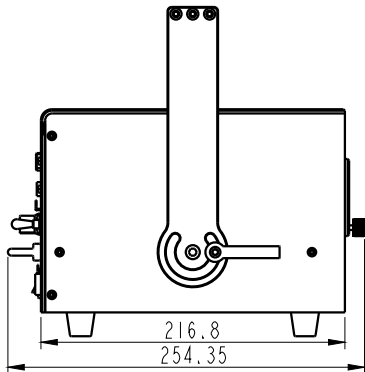
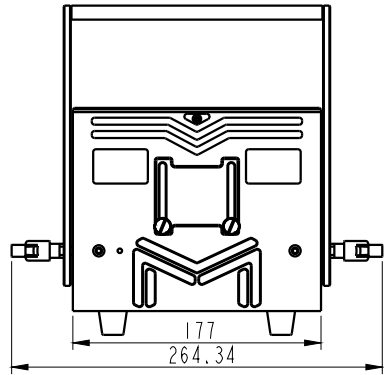
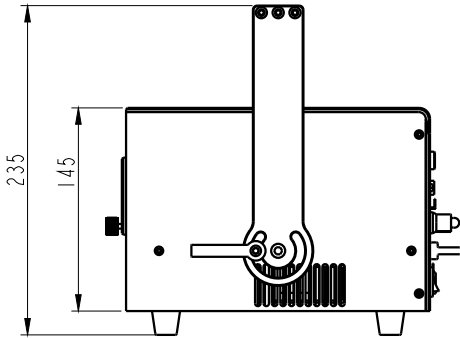
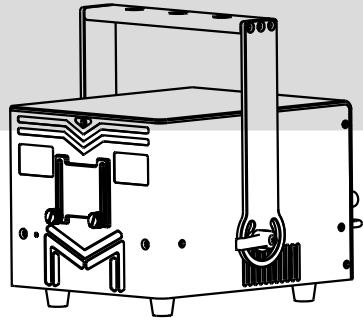

## INTRODUCTIONS of PR5 SERIES

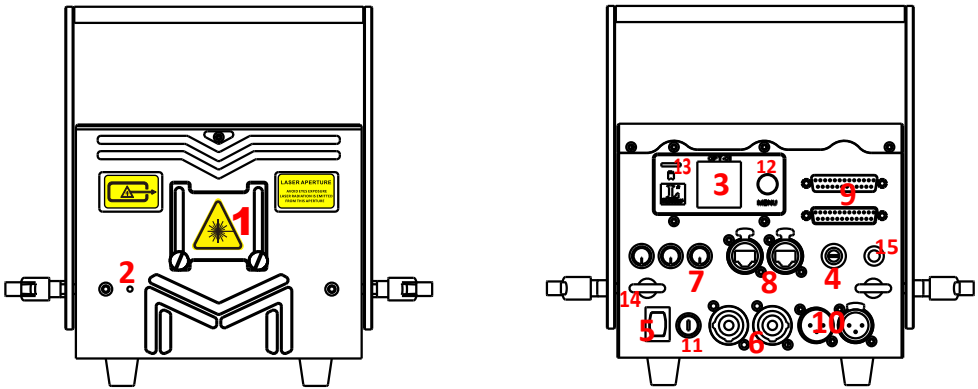

<b>1</b>	<b>Laser aperture</b>	(covered by masking plate) DO NOT look directly into this aperture once the masking plate gets loosen
<b>2</b>	<b>Laser Emission</b>	When this indicator is lit up the laser system is ready to emit the laser radiation as soon as it receives instructions from control software.
<b>3</b>	<b>LCD Display</b>	Integrated with multi settings on the projector, please refer to detailed settings (on Page 11. ) for the LCD
<b>4</b>	<b>Keyhole</b>	Safety key, laser output is available when the key is moved to position “on”
<b>5</b>	<b>Power Switch</b>	Power On/Off
<b>6</b>	<b>PowerCON Input &amp; Output</b>	Power connectors input and output
<b>7</b>	<b>Color intensity knobs</b>	R/G/B power intensity adjustments, rotate or anti-rotate to adjust output power
<b>8</b>	<b>INTERLOCK (RJ45 jack)</b>	Laser output is available only when the interlock is connected. It could be used to connect a laser emergency switch(E-stop box).
<b>9</b>	<b>ILDA Input &amp; Output</b>	DB25 connections input and output for ILDA mode display
<b>10</b>	<b>DMX Input &amp; Output</b>	3-pin DMX connections input and thru for DMX512 mode display
<b>11</b>	<b>FUSE</b>	Safety element; current rating 4Amps
<b>12</b>	<b>Menu knob for LCD Setting</b>	The knob for the main settings on LCD, click it to wake the LCD and rotate it for corresponding status setting
<b>13</b>	<b>SD-Card Slot</b>	Slot for SD-Card which you may have your own laser files to export on
<b>14</b>	<b>Safety Ring</b>	The ring for enwinding a safety rope when the laser device will be installed on out-of-reach locations.
<b>15</b>	<b>SFS</b>	Scan-fail safety switch

## Specifications of PR5 SERIES

<b>Type of Laser</b>	Pure diode-based full colors(semiconductor diode laser systems)																									
<b>Laser Classification</b>	Class 4																									
<b>Laser Power(mW)</b>	<table border="1"> <thead> <tr> <th>Model</th> <th><math>\lambda</math></th> <th>638nm</th> <th>520nm</th> <th>445nm or 465nm</th> </tr> </thead> <tbody> <tr> <td>PR3000A-RGB</td> <td>R/700mW+G/1200mW+B/1600mW</td> <td></td> <td></td> <td></td> </tr> <tr> <td>PR4000A-RGB</td> <td>R/700mW+G/1400mW+B/2000mW</td> <td></td> <td></td> <td></td> </tr> <tr> <td>PR6000A-RGB</td> <td>R/1400mW+G/1500mW+B/3000mW</td> <td></td> <td></td> <td></td> </tr> <tr> <td>PR8000A-RGB</td> <td>R/2200mW+G/1700mW+B/4500mW</td> <td></td> <td></td> <td></td> </tr> </tbody> </table>	Model	$\lambda$	638nm	520nm	445nm or 465nm	PR3000A-RGB	R/700mW+G/1200mW+B/1600mW				PR4000A-RGB	R/700mW+G/1400mW+B/2000mW				PR6000A-RGB	R/1400mW+G/1500mW+B/3000mW				PR8000A-RGB	R/2200mW+G/1700mW+B/4500mW			
Model	$\lambda$	638nm	520nm	445nm or 465nm																						
PR3000A-RGB	R/700mW+G/1200mW+B/1600mW																									
PR4000A-RGB	R/700mW+G/1400mW+B/2000mW																									
PR6000A-RGB	R/1400mW+G/1500mW+B/3000mW																									
PR8000A-RGB	R/2200mW+G/1700mW+B/4500mW																									
<b>Scanning-system</b>	40kpps ILDA@8° , Scan angle Max 60°																									
<b>Beam Size@aperture</b>	3.0*6.0 mm																									
<b>Beam Divergence</b>	< 1.2 mRad																									
<b>Modulation</b>	>100 KHz																									
<b>Power Supply</b>	AC 100-240V, 50/60Hz																									
<b>Power Consumption</b>	70   75   85   90W																									
<b>Net Weight</b>	4.80kg																									
<b>Dimension</b>	254*177*145mm																									
<b>Controls</b>	Auto[ZLDA], Test, DMX512 , ILDA																									
<b>Operation Temperature</b>	minus20℥ to 40℥																									
<b>Protection Rating</b>	IP54																									
<b>Safety elements</b>	Keyed interlock, emission delay, magnetic interlock, scan-fail safety, mechanical shutter, adjustable aperture masking plate.																									
<b>Important statement</b>	Due to Advanced Optical Correction technology used in our laser systems the optical power output of each laser colour within the system may slightly differ from the specification of respective laser module(s) installed. This does not affect the total guaranteed power output.																									

**PT6 SERIES**

Standard Versions(without FB4 built-in)

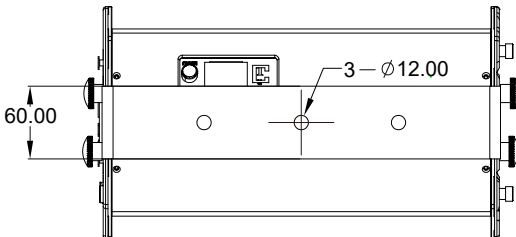
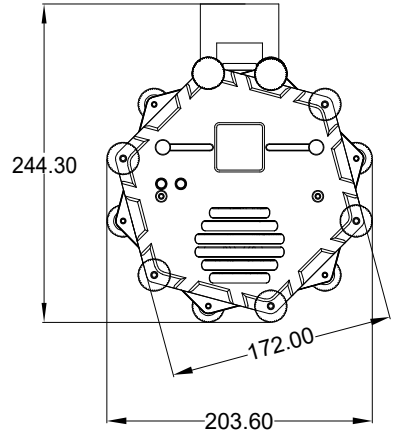
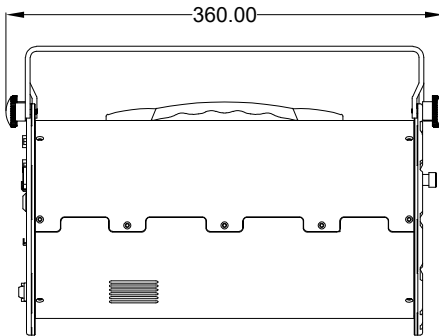
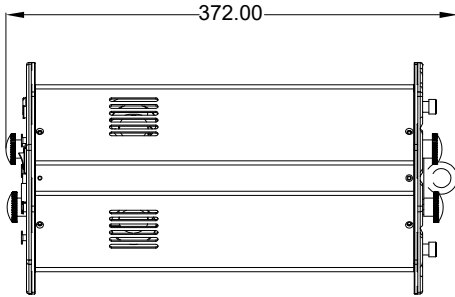
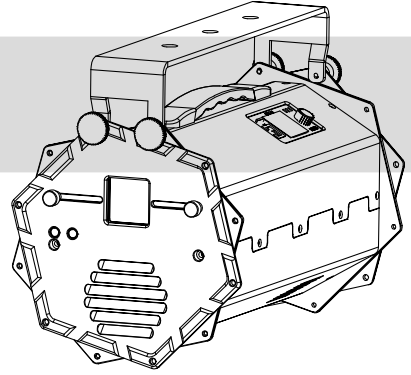

## INTRODUCTIONS of PT6 SERIES

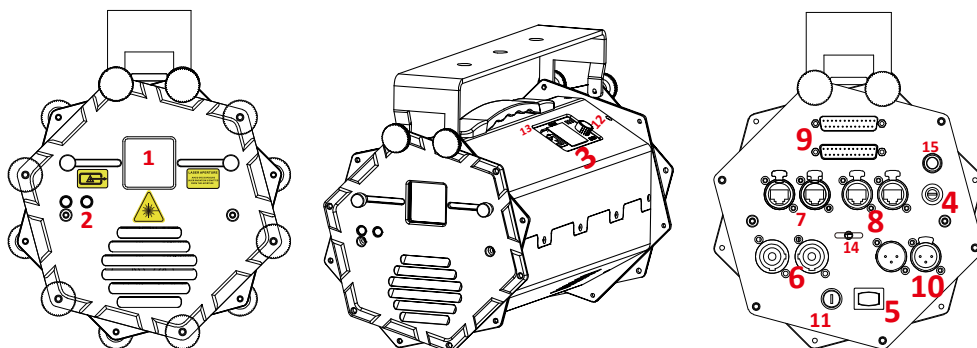

<b>1</b>	<b>Laser aperture</b>	(covered by masking plates) DO NOT look directly into this aperture once the masking plate gets loosen
<b>2</b>	<b>Laser Emission indicators</b>	When this indicator is lit up the laser system is ready to emit the laser radiation as soon as it receives instructions from control software.
<b>3</b>	<b>LCD Display</b>	Integrated with multi settings on the projector, please refer to detailed settings (on Page 11. ) for the LCD
<b>4</b>	<b>Keyhole</b>	Safety key, laser output is available when the key is moved to position “on”
<b>5</b>	<b>Power Switch</b>	Power On/Off
<b>6</b>	<b>PowerCON Input &amp; Output</b>	Power connectors input and output
<b>7</b>	<b>ILDA to RJ45</b>	Standard ILDA DB25 converted to RJ45 connector(8pin) which covers only the signals R, G, B, scan +X, +Y,-X,-Y and GND; Only for the desire of easy cabelling.
<b>8</b>	<b>INTERLOCK (RJ45 jack)</b>	Laser output is available only when the interlock is connected. It could be used to connect a laser emergency switch(E-stop box).
<b>9</b>	<b>ILDA Input &amp; Output</b>	DB25 connections input and output for ILDA mode display
<b>10</b>	<b>DMX Input &amp; Output</b>	XLR 3pin DMX connections input and thru for DMX512 mode display
<b>11</b>	<b>FUSE</b>	Safety element; current rating 4Amps
<b>12</b>	<b>Menu knob for LCD Setting</b>	The knob for the main settings on LCD, click it to wake the LCD and rotate it for corresponding status setting
<b>13</b>	<b>SD-Card Slot</b>	Slot for SD-Card which you may have your own laser files to export on
<b>14</b>	<b>Safety Ring</b>	The ring for enwinding a safety rope when the laser device will be installed on out-of-reach locations.
<b>15</b>	<b>SFS</b>	Scan-fail safety switch

## Specifications of PT6 SERIES

<b>Type of Laser</b>	Pure diode-based full colors(semiconductor diode laser systems)															
<b>Laser Classification</b>	Class 4															
<b>Laser Power(mW)</b>	<table border="1"> <thead> <tr> <th>Model</th> <th><math>\lambda</math></th> <th>638nm</th> <th>520nm</th> <th>445nm or 465nm</th> </tr> </thead> <tbody> <tr> <td>PR6000A-RGB</td> <td>R/1950mW+G/2000mW+B/3000mW</td> <td></td> <td></td> <td></td> </tr> <tr> <td>PR8000A-RGB</td> <td>R/1950mW+G/2400mW+B/4000mW</td> <td></td> <td></td> <td></td> </tr> </tbody> </table>	Model	$\lambda$	638nm	520nm	445nm or 465nm	PR6000A-RGB	R/1950mW+G/2000mW+B/3000mW				PR8000A-RGB	R/1950mW+G/2400mW+B/4000mW			
Model	$\lambda$	638nm	520nm	445nm or 465nm												
PR6000A-RGB	R/1950mW+G/2000mW+B/3000mW															
PR8000A-RGB	R/1950mW+G/2400mW+B/4000mW															
<b>Scanning-system</b>	40kpps ILDA@8° , Scan angle Max 60°															
<b>Beam Size@aperture</b>	4.0*6.0 mm															
<b>Beam Divergence</b>	< 1.2 mRad															
<b>Modulation</b>	>100 KHz															
<b>Power Supply</b>	AC 100-240V, 50/60Hz															
<b>Power Consumption</b>	75   95W															
<b>Net Weight</b>	5.30kg															
<b>Dimension</b>	372*172*172mm															
<b>Controls</b>	Auto[ZLDA], Test, DMX512 , ILDA, ILDA-RJ45															
<b>Operation Temperature</b>	minus20¥ to 40¥															
<b>Protection Rating</b>	IP54															
<b>Safety elements</b>	Keyed interlock, emission delay, magnetic interlock, scan-fail safety, mechanical shutter, adjustable aperture masking plate.															
<b>Important statement</b>	Due to Advanced Optical Correction technology used in our laser systems the optical power output of each laser colour within the system may slightly differ from the specification of respective laser module(s) installed. This does not affect the total guaranteed power output.															

**PR10 SERIES**

Standard Versions(without FB4 built-in)

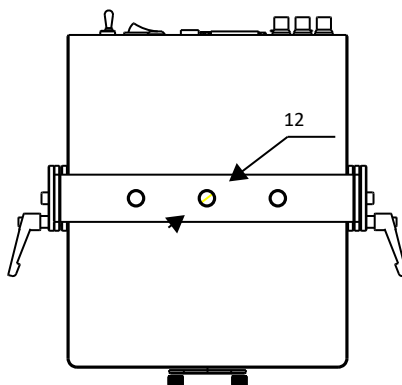
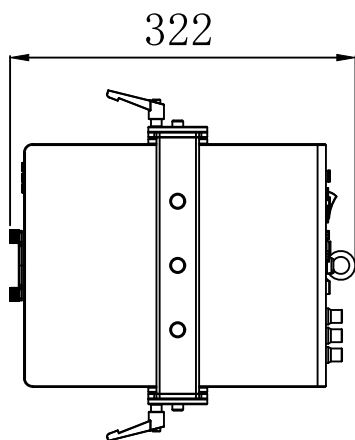
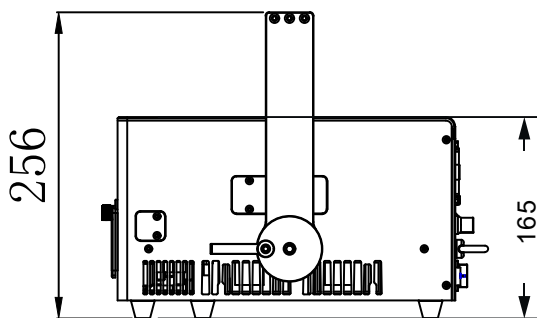
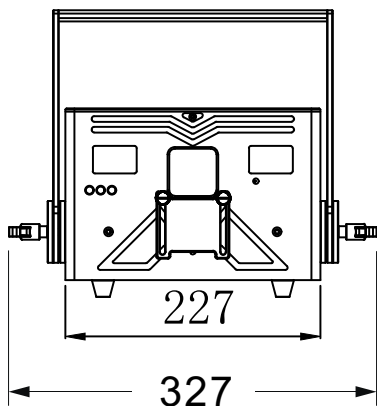
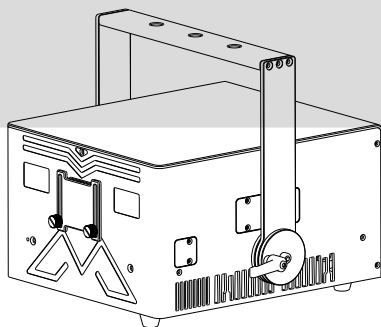

## INTRODUCTIONS of PR10 SERIES

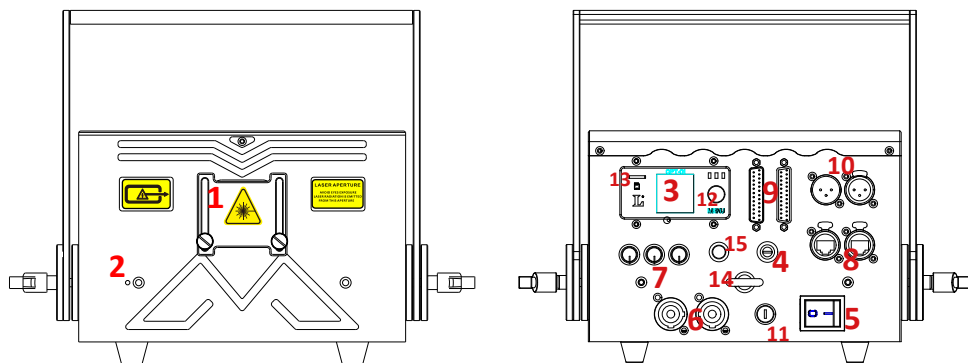

<b>1</b>	<b>Laser aperture</b>	(covered by masking plate) DO NOT look directly into this aperture once the masking plate gets loosen
<b>2</b>	<b>Laser Emission</b>	When this indicator is lit up the laser system is ready to emit the laser radiation as soon as it receives instructions from control software.
<b>3</b>	<b>LCD Display</b>	Integrated with multi settings on the projector, please refer to detailed settings (on Page 11. ) for the LCD
<b>4</b>	<b>Keyhole</b>	Safety key, laser output is available when the key is moved to position “on”
<b>5</b>	<b>Power Switch</b>	Power On/Off
<b>6</b>	<b>PowerCON Input &amp; Output</b>	Power connectors input and output
<b>7</b>	<b>Color intensity knobs</b>	R/G/B power intensity adjustments, rotate or anti-rotate to adjust output power
<b>8</b>	<b>INTERLOCK (RJ45 jack)</b>	Laser output is available only when the interlock is connected. The dual sockets can be used to connect a laser emergency stop box.
<b>9</b>	<b>ILDA Input &amp; Output</b>	DB25 connections input and output for ILDA mode display
<b>10</b>	<b>DMX Input &amp; Output</b>	3-pin DMX connections input and thru for DMX512 mode display
<b>11</b>	<b>FUSE</b>	Safety element; current rating 8Amps
<b>12</b>	<b>Menu knob for LCD Setting</b>	The knob for the main settings on LCD, click it to wake the LCD and rotate it for corresponding status setting
<b>13</b>	<b>SD-Card Slot</b>	Slot for SD-Card which you may have your own laser files to export on
<b>14</b>	<b>Safety Ring</b>	The ring for enwinding a safety rope when the laser device will be installed on out-of-reach locations.
<b>15</b>	<b>SFS</b>	Scan-fail safety switch

## Specifications of PR10 SERIES

<b>Type of Laser</b>	Pure diode-based full colors(semiconductor diode laser systems)																									
<b>Laser Classification</b>	Class 4																									
<b>Laser Power(mW)</b>	<table border="1"> <thead> <tr> <th>Model</th> <th><math>\lambda</math></th> <th>638nm</th> <th>520nm</th> <th>445nm or 465nm</th> </tr> </thead> <tbody> <tr> <td>PR14000-RGB</td> <td>R/4200mW+G/4800mW+B/5500mW(445nm)</td> <td></td> <td></td> <td></td> </tr> <tr> <td>PR13000-RGB</td> <td>R/4200mW+G/4600mW+B/5000mW(465nm)</td> <td></td> <td></td> <td></td> </tr> <tr> <td>PR10000-RGB</td> <td>R/3000mW+G/3200mW+B/5000mW(445nm)</td> <td></td> <td></td> <td></td> </tr> <tr> <td>PR9000-RGB</td> <td>R/2800mW+G/3200mW+B/3000mW(465nm)</td> <td></td> <td></td> <td></td> </tr> </tbody> </table>	Model	$\lambda$	638nm	520nm	445nm or 465nm	PR14000-RGB	R/4200mW+G/4800mW+B/5500mW(445nm)				PR13000-RGB	R/4200mW+G/4600mW+B/5000mW(465nm)				PR10000-RGB	R/3000mW+G/3200mW+B/5000mW(445nm)				PR9000-RGB	R/2800mW+G/3200mW+B/3000mW(465nm)			
Model	$\lambda$	638nm	520nm	445nm or 465nm																						
PR14000-RGB	R/4200mW+G/4800mW+B/5500mW(445nm)																									
PR13000-RGB	R/4200mW+G/4600mW+B/5000mW(465nm)																									
PR10000-RGB	R/3000mW+G/3200mW+B/5000mW(445nm)																									
PR9000-RGB	R/2800mW+G/3200mW+B/3000mW(465nm)																									
<b>Scanning-system</b>	40kpps ILDA@8° , Scan angle Max 60°																									
<b>Beam Size@aperture</b>	3.5*7.0 mm																									
<b>Beam Divergence</b>	< 1.0 mRad																									
<b>Modulation</b>	>100 KHz																									
<b>Power Supply</b>	AC 100-240V, 50/60Hz																									
<b>Power Consumption</b>	170   175   185   210W																									
<b>Net Weight</b>	9.6kg																									
<b>Dimension</b>	313*237*153mm																									
<b>Controls</b>	Auto[ZLDA], DMX512 , ILDA																									
<b>Operation Temperature</b>	minus20℥ to 40℥																									
<b>Protection Rating</b>	IP54																									
<b>Safety elements</b>	Keyed interlock, emission delay, magnetic interlock, scan-fail safety, mechanical shutter, adjustable aperture masking plate.																									
<b>Important statement</b>	Due to Advanced Optical Correction technology used in our laser systems the optical power output of each laser colour within the system may slightly differ from the specification of respective laser module(s) installed. This does not affect the total guaranteed power output.																									

**CF20 SERIES**

Standard Versions(without FB4 built-in)

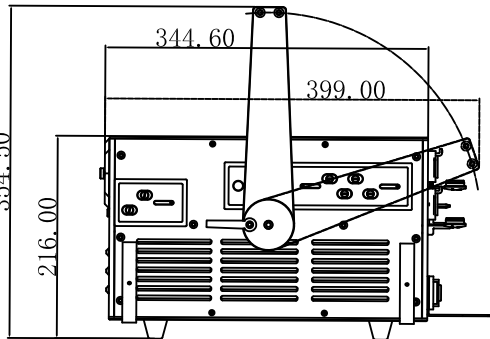
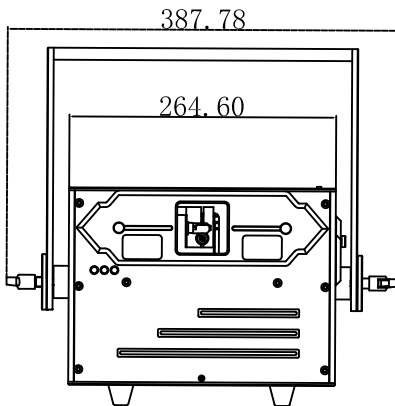
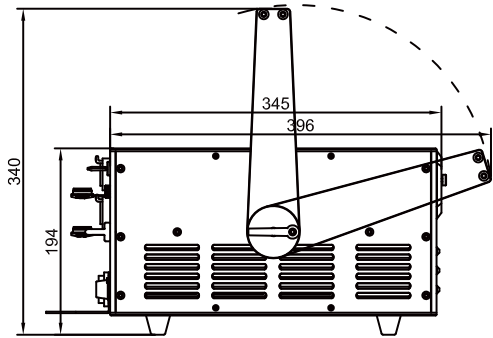
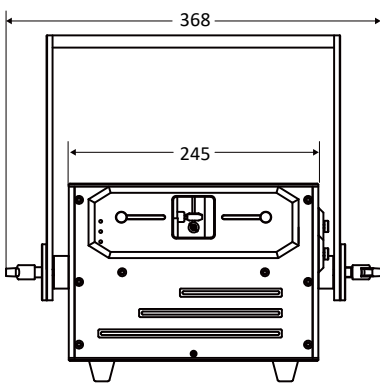
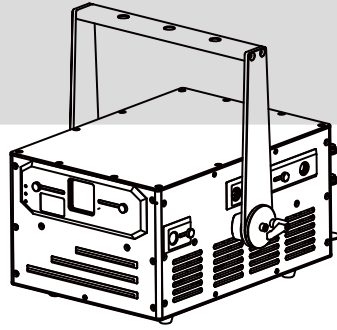

**CF30 SERIES**

Standard Versions(without FB4 built-in)

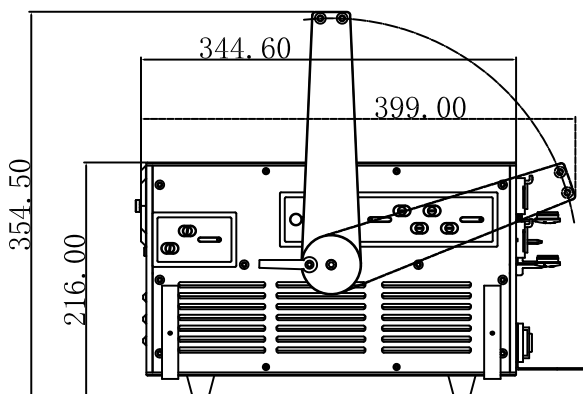
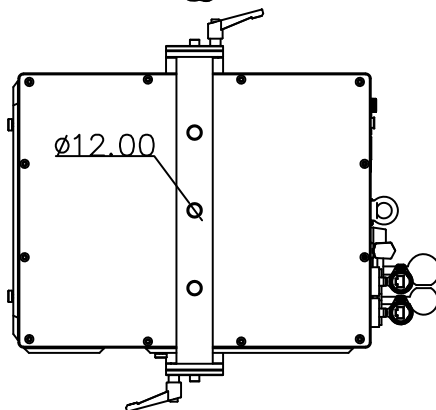
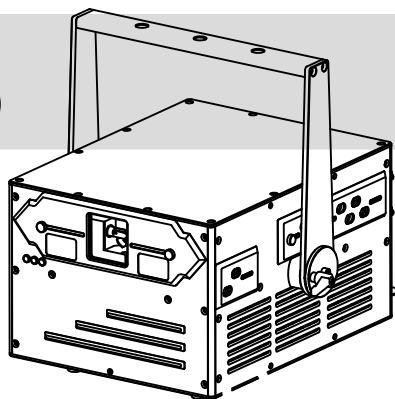
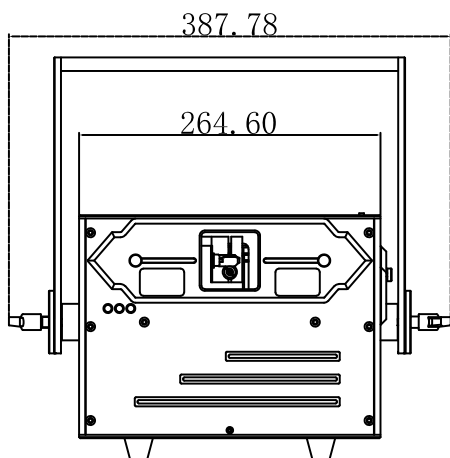

## INTRODUCTIONS of CF20|CF30 SERIES

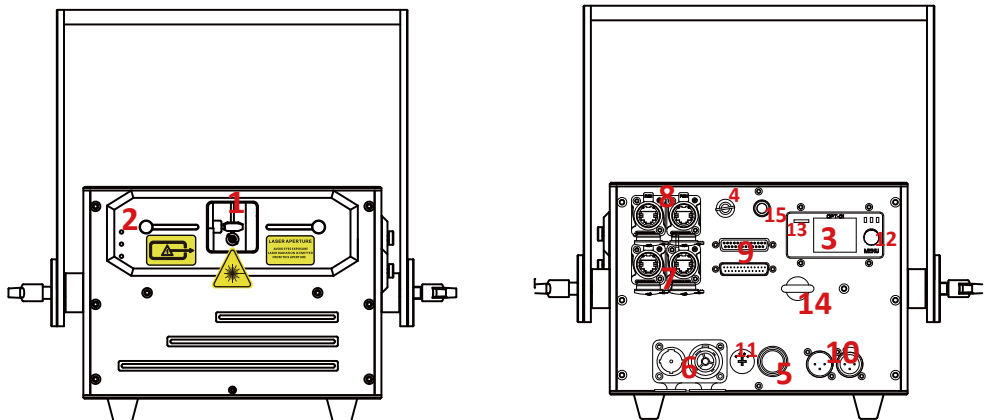

<b>1</b>	<b>Laser aperture</b>	(covered by masking plate) DO NOT look directly into this aperture once the masking plate gets loosen
<b>2</b>	<b>Laser Emission indicators</b>	When the red indicator is lit up the laser system is ready to emit the laser radiation as soon as it receives instructions from control board or software.
<b>3</b>	<b>LCD Display</b>	Integrated with multi settings on the projector, please refer to detailed settings (on Page 11. ) for the LCD
<b>4</b>	<b>Keyhole</b>	Safety key, laser output is available when the key is moved to position “on”
<b>5</b>	<b>Power Switch</b>	Power On/Off
<b>6</b>	<b>PowerCON Input &amp; Output</b>	True 1 Power connectors input and output
<b>7</b>	<b>ILDA-RJ45 Jacks</b>	The RJ45 adapter that signal is converted from standard ILDA board, for the purpose of flexible cabling on gigs if ILDA cables are not preferred.
<b>8</b>	<b>INTERLOCK (RJ45 jack)</b>	Laser output is available only when the interlock is connected. It could be used to connect a laser emergency switch(E-stop box).
<b>9</b>	<b>ILDA Input &amp; Output</b>	DB25 connectors input and output for ILDA mode display
<b>10</b>	<b>DMX Input &amp; Output</b>	3-pin xlr DMX connections input and thru for DMX512 mode display
<b>11</b>	<b>FUSE</b>	Safety element; current rating 8Amps
<b>12</b>	<b>Menu knob for LCD Setting</b>	The knob for the main settings on LCD, click it to wake the LCD and rotate it for corresponding status setting
<b>13</b>	<b>SD-Card Slot</b>	Slot for SD-Card which you may have your own laser files to export on
<b>14</b>	<b>Safety Ring</b>	The ring for enwinding a safety rope when the laser device will be installed on out-of-reach locations.
<b>15</b>	<b>SFS</b>	Scan-fail safety switch

## Specifications of CF20 | 30 SERIES

<b>Type of Laser</b>	Pure diode-based full colors(semiconductor diode laser systems)																									
<b>Laser Classification</b>	Class 4																									
<b>Laser Power(mW)</b>	<table border="1"> <thead> <tr> <th>Model</th> <th><math>\lambda</math></th> <th>638nm</th> <th>520nm</th> <th>445nm or 465nm</th> </tr> </thead> <tbody> <tr> <td>CF33000-RGB</td> <td>R/8500mW+G/10000mW+B/15000mW</td> <td></td> <td></td> <td></td> </tr> <tr> <td>CF30000-RGB</td> <td>R/8500mW+G/10000mW+B/12500mW</td> <td></td> <td></td> <td></td> </tr> <tr> <td>CF24000-RGB</td> <td>R/7000mW+G/8000mW+ B/9000mW</td> <td></td> <td></td> <td></td> </tr> <tr> <td>CF20000-RGB</td> <td>R/5600mW+G/6000mW+ B/8500mW</td> <td></td> <td></td> <td></td> </tr> </tbody> </table>	Model	$\lambda$	638nm	520nm	445nm or 465nm	CF33000-RGB	R/8500mW+G/10000mW+B/15000mW				CF30000-RGB	R/8500mW+G/10000mW+B/12500mW				CF24000-RGB	R/7000mW+G/8000mW+ B/9000mW				CF20000-RGB	R/5600mW+G/6000mW+ B/8500mW			
Model	$\lambda$	638nm	520nm	445nm or 465nm																						
CF33000-RGB	R/8500mW+G/10000mW+B/15000mW																									
CF30000-RGB	R/8500mW+G/10000mW+B/12500mW																									
CF24000-RGB	R/7000mW+G/8000mW+ B/9000mW																									
CF20000-RGB	R/5600mW+G/6000mW+ B/8500mW																									
<b>Scanning-system</b>	40kpps ILDA@8° , Scan angle Max 60°																									
<b>Beam Size@aperture</b>	CF20: 5.0*7.0 mm   CF30: 6.5*7.0mm																									
<b>Beam Divergence</b>	< 1.0 mRad																									
<b>Modulation</b>	>100 KHz																									
<b>Power Supply</b>	AC 100-240V, 50/60Hz																									
<b>Power Consumption</b>	300   350   400																									
<b>Net Weight</b>	12.80kg   14.60kg																									
<b>Dimension</b>	373*270*211mm																									
<b>Controls</b>	Auto[ZLDA], DMX512 , ILDA																									
<b>Operation Temperature</b>	minus20¥ to 40¥																									
<b>Protection Rating</b>	IP54																									
<b>Safety elements</b>	Interlock, emission delay, magnetic interlock, scan-fail safety, mechanical shutter, adjustable aperture masking plate.																									
<b>Important statement</b>	Due to Advanced Optical Correction technology used in our laser systems the optical power output of each laser colour within the system may slightly differ from the specification of respective laser module(s) installed. This does not affect the total guaranteed power output.																									

**WP35 SERIES**

Standard Versions(without FB4 built-in)

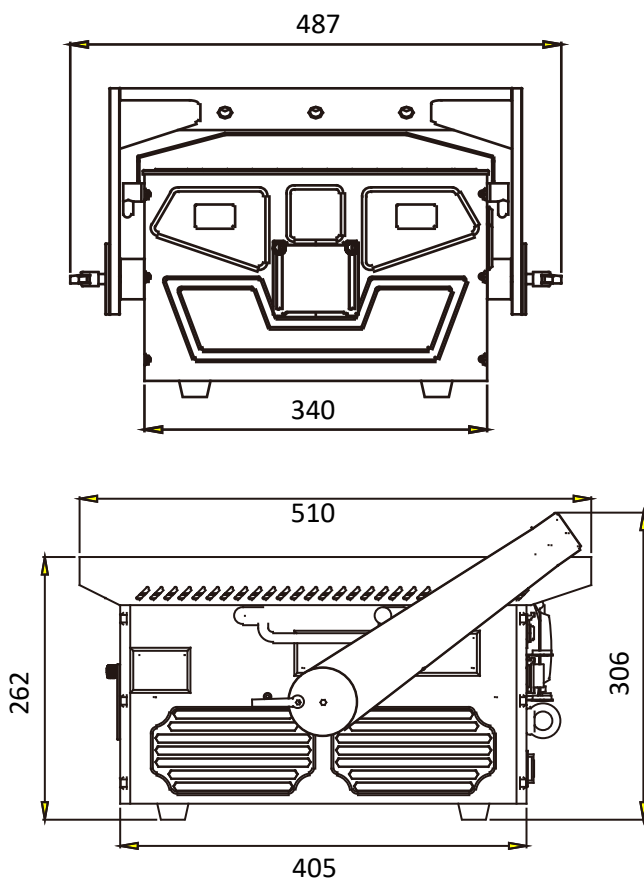
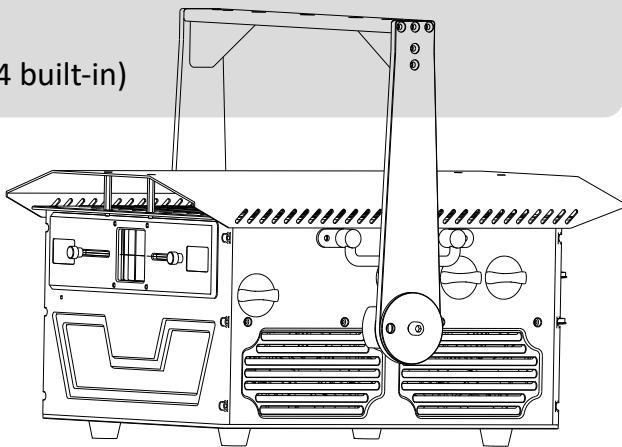

## INTRODUCTIONS of WP35 SERIES

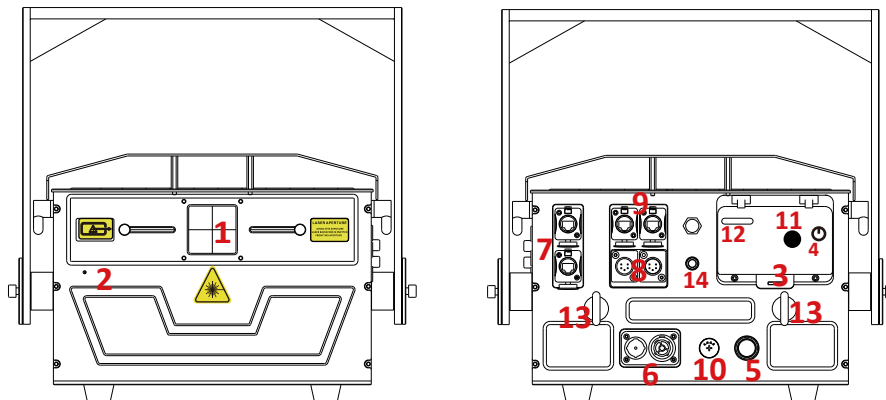

<b>1</b>	<b>Laser aperture</b>	(covered by masking plate) DO NOT look directly into this aperture once the masking plate gets loosen
<b>2</b>	<b>Laser Emission indicators</b>	When the red indicator is lit up the laser system is ready to emit the laser radiation as soon as it receives instructions from control board or software.
<b>3</b>	<b>LCD Display</b>	Integrated with multi settings on the projector, please refer to detailed settings (on Page 11. ) for the LCD
<b>4</b>	<b>Keyhole</b>	Safety key, laser output is available when the key is moved to position “on”
<b>5</b>	<b>Power Switch</b>	Power On/Off
<b>6</b>	<b>PowerCON Input &amp; Output</b>	True 1 Power connectors input and output
<b>7</b>	<b>INTERLOCK (RJ45 jack)</b>	Laser output is available only when the interlock is connected. It could be used to connect a laser emergency switch(E-stop box).
<b>8</b>	<b>ILDA Input &amp; Output</b>	DB25 connectors converted to XLR 12PIN as ILDA IN&OUT.
<b>9</b>	<b>DMX Input &amp; Output</b>	3-pin xlr DMX connectors input and thru for DMX512 mode display
<b>10</b>	<b>FUSE</b>	Safety element; current rating 8Amps
<b>11</b>	<b>Menu knob for LCD Setting</b>	The knob for the main settings on LCD, click it to wake the LCD and rotate it for corresponding status setting
<b>12</b>	<b>SD-Card Slot</b>	Slot for SD-Card which you may have your own laser files to export on
<b>13</b>	<b>Safety Rings</b>	The ring for enwinding a safety rope when the laser device will be installed on out-of-reach locations.
<b>14</b>	<b>SFS</b>	Scan-fail safety switch

## Specifications of WP35 SERIES

<b>Type of Laser</b>	Pure diode-based full colors(semiconductor diode laser systems)															
<b>Laser Classification</b>	Class 4															
<b>Laser Power(mW)</b>	<table border="1"> <thead> <tr> <th>Model</th> <th><math>\lambda</math></th> <th>638nm</th> <th>520nm</th> <th>445nm</th> </tr> </thead> <tbody> <tr> <td>WP35000-RGB</td> <td>R/10000mW+G/12000mW+B/13000mW(445+465nm)</td> <td></td> <td></td> <td></td> </tr> <tr> <td>WP37000-RGB</td> <td>R/10000mW+G/12000mW+B/15000mW</td> <td></td> <td></td> <td></td> </tr> </tbody> </table>	Model	$\lambda$	638nm	520nm	445nm	WP35000-RGB	R/10000mW+G/12000mW+B/13000mW(445+465nm)				WP37000-RGB	R/10000mW+G/12000mW+B/15000mW			
Model	$\lambda$	638nm	520nm	445nm												
WP35000-RGB	R/10000mW+G/12000mW+B/13000mW(445+465nm)															
WP37000-RGB	R/10000mW+G/12000mW+B/15000mW															
<b>Scanning-system</b>	30kpps ILDA@8° , Scan angle Max 60°															
<b>Beam Size@aperture</b>	7.5*7.0 mm															
<b>Beam Divergence</b>	< 1.0mRad															
<b>Modulation</b>	>100 KHz															
<b>Power Supply</b>	AC 100-240V, 50/60Hz															
<b>Power Consumption</b>	490															
<b>Net Weight</b>	24.50kg															
<b>Dimension</b>	405*354*210mm															
<b>Controls</b>	Auto[ZLDA], DMX512 , ILDA															
<b>Operation Temperature</b>	minus20℥ to 40℥															
<b>Protection Rating</b>	IP65															
<b>Safety elements</b>	Interlock, emission delay, magnetic interlock, scan-fail safety, mechanical shutter, adjustable aperture masking plate.															
<b>Important statement</b>	Due to Advanced Optical Correction technology used in our laser systems the optical power output of each laser colour within the system may slightly differ from the specification of respective laser module(s) installed. This does not affect the total guaranteed power output.															

**WP45 Series**

Standard Versions(without FB4 built-in)

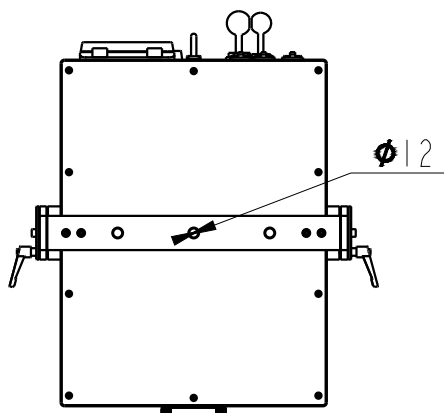
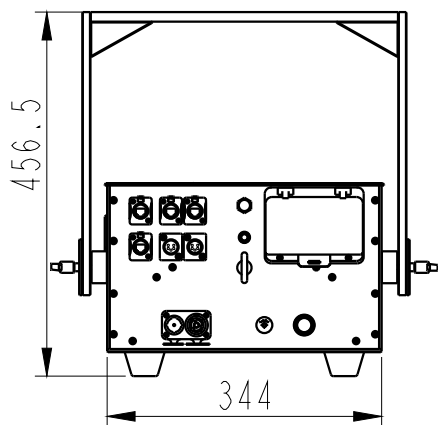
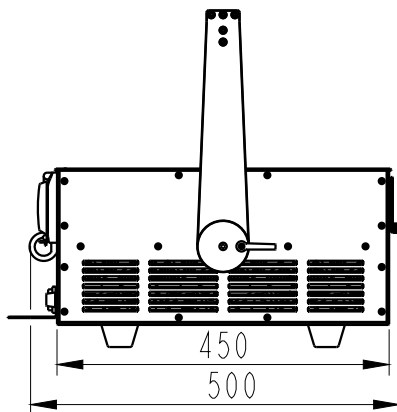
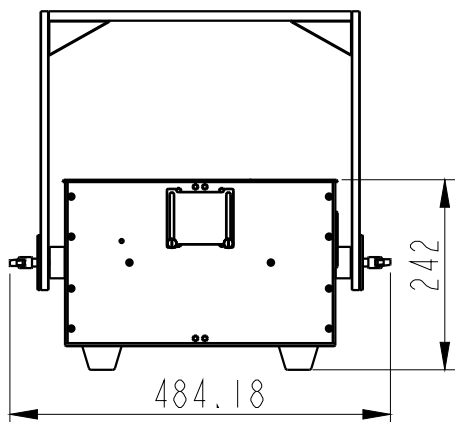

## WP45 Series INTRODUCTIONS

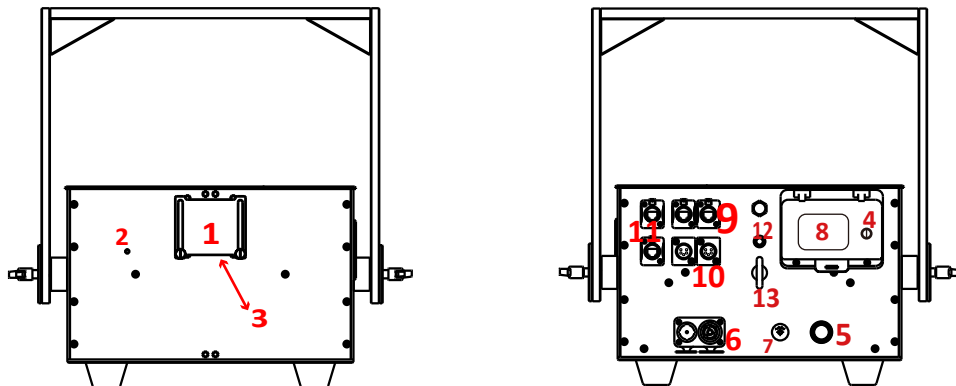

<b>1</b>	<b>Laser aperture</b>	(Covered by masking plate) DO NOT look directly into this aperture once the masking plate gets loosen
<b>2</b>	<b>Laser Emission</b>	When this indicator is lit up the laser system is ready to emit the laser radiation as soon as it receives instructions from control software.
<b>3</b>	<b>Masking plates</b>	Sliding masking plates. Protection for laser aperture and sometimes can be used as the Y-axis' projection scale adjustments by sliding the plates.
<b>4</b>	<b>Safety key</b>	Key Switch, laser output is allowed when the key is moved to position "on"
<b>5</b>	<b>Power Switch</b>	Power On/Off
<b>6</b>	<b>PowerCON Input &amp; Output</b>	True 1 power input and output sockets. With output feature you can connect the device to another or more devices are using the same input and output sockets. They must be the same phase, DO NOT mix up.
<b>7</b>	<b>FUSE</b>	Current rating 8.0Amp
<b>8</b>	<b>Mainboard(LCD controller) (covered by IP67 lid)</b>	Integrated with multi settings on the projector, please refer to detailed settings (on Page 11. ) for the LCD
<b>9</b>	<b>ILDA Input &amp; Thru</b>	DB25 connectors converted to XLR 12PIN as ILDA IN&OUT.
<b>10</b>	<b>DMX or ILDA interface</b>	3pin DMX connections input and thru for DMX512 mode display or 12-pin conversions to standard Sub DB25 ILDA connections only one of above interfaces is available due to the limit of the back panel
<b>11</b>	<b>INTERLOCK IN/THRU</b>	Laser output is available only when the interlock is connected. It could be used to connect a laser emergency switch(E-stop box).
<b>12</b>	<b>SFS Button</b>	Scan-fail safety button, a protection feature for preventing the straight single laser beam from outputing when if the scanner set is malfunctioning or the laser cue's size is intentionally set to too small scale such as 10. And this safety/protection can only be activated when the button is pressed down.
<b>13</b>	<b>Safety Ring</b>	The ring for enwinding a safety cable when the laser device will be installed on out-of-reach locations.

## Specifications of WP45 SERIES

<b>Type of Laser</b>	Pure diode-based full colors(semiconductor diode laser systems)			
<b>Laser Classification</b>	Class 4			
<b>Laser wavelength</b>	<b>Model</b>	$\lambda$ 638nm	520nm	445 or 465nm
<b>Laser Power(mW)</b>	WP45000-RGB	13000mW	15000mW	18000mW
	WP48000-RGB	13000mW	15000mW	20000mW
<b>Scanning-system</b>	25kpps ILDA@8° , Scan angle Max 40°			
<b>Beam Size@aperture</b>	6.5*12 mm			
<b>Beam Divergence</b>	<1.0 mRad			
<b>Modulation</b>	>100 KHz			
<b>Power Supply</b>	AC 100-240V, 50/60Hz			
<b>Power Consumption(W)</b>	650			
<b>Net Weight</b>	~29 kg			
<b>Dimension</b>	500*344*242 mm			
<b>Controls</b>	Ethernet/ArtNet/DMX/ILDA			
<b>Operation Temperature</b>	minus20¥ to 40¥			
<b>Protection Rating</b>	IP65			
<b>Safety elements</b>	Safety key, emission delay, magnetic shutter, scan-fail safety, adjustable aperture masking plate.			
<b>Important statement</b>	Due to Advanced Optical Correction technology used in our laser systems the optical power output of each laser colour within the system may slightly different from the specification of respective laser module(s) installed. This does not affect the total guaranteed power output.			

## DMX Charts

## 16 CHs

CH	Value	Descriptions	Width
1	0-255 _ DMX model	0-31 _ Close the light 33-95 _ Top 4 channels 97-159 _ Top 8 channels 161-232 _ Top 12 channels 225-255 _ Top 16 channels	8 Bit
2	0-255 _ Page index ( 9 in total Page )	0-15 _ Page 1 17-31 _ Page 2 33-47 _ Page 3 49-63 _ Page 4 65-79 _ Page 5 81-95 _ Page 6 97-111 _ Page 7 113-127 _ Page 8 129-255 _ Page 9	8 Bit
3	0-255 _ program index ( 48 in total programme )	0-32 _ Close the light 33-35 _ Program 1 37-39 _ Program 2 .. - .. .. 221-223 _ Program 48 225-255 _ -- --	8 Bit
4	0-255 _ speed	0-15 _ Default speed 17-31 _ pause 33-255 _ 25% ~ 200%	8 Bit
5	0-255 _ brightness	0% ~ 100%	8 Bit
6	0-255 _ size	0%~ 100%	8 Bit
7	0-255 _ X size	-100% ~ 100%	8 Bit
8	0-255 _ Y size	-100% ~ 100%	8 Bit
9	0-255 _ Z angle	0~360 deg	8 Bit
10	0-255 _ X position	0 = left , 128 = center , 255 = right	8 Bit
11	0-255 _ Y position	0 = top , 128 = mid , 255 = bottom	8 Bit
12	0-255 _ Visible point	0 ~ 100%	8 Bit
13	0-255 _ scan rate	0-31 _ Default scan rate 33-223 _ 6K ~ 29K 225-255 _ 30K	8 Bit
14	0-255 _ reserve		8 Bit
15	0-255 color table	0-31 original color 33- 223 color table 225- 255 white	8 Bit
16	0-255 Reserved	Reserved	8 Bit

## DMX Charts

## 26 CHs

CH	Value	Description	Width
1	0-255 page index	page index , 0~3 light off 4~7 No. 1 Page 8~ 11 2nd Page 12~15 No. 3 Page ... 252~255 No. 63 Page	8 Bit
2	0-255 program index	program index 0~3 light off 4~7 No. 1 programme 8~ 11 2nd programme 12~15 No. 3 programme ... 252~255 No. 63 programme	8 Bit
3	0-255 playback speed	(0 = original speed , 1 - 255 = 1% ~ 255%)	8 Bit
4	0-255 brightness _	(0 ~ 100%)	8 Bit
5,6	0-65535 size	(0 ~ 100%)	16 Bit
7,8	0-65535X _size	(-100 ~ 100%, 0 = 32768)	16 Bit
9,10	0-65535 Y size	(-100 ~ 100%, 0 = 32768)	16 Bit
11,12	0-65535 Z angle	Rotation angle (0~ 360 ° )	16 Bit
13,14	0-65535Z _rotate	Rotation speed -60 ~ 60 Rpm ( 0 = original position , 1 ~ 32767 = -100% ~ -1 % Rotation speed , 32768 = Save stationary and not rotating , 32769 ~ 65535 = 1% ~ 100% Rotating speed )	
15,16	0-65535X _Location	(-100 ~ 100%, 0 = 32768)	16 Bit
17,18	0-65535 Y Location	(-100 ~ 100%, 0 = 32768)	16 Bit
19	0-255 scan rate	(5k ~ 30K)	8 Bit
20	0-255 red light brightness	(0 ~ 100%)	8 Bit
21	0-255 green light brightness	(0 ~ 100%)	8 Bit
22	0-255 blue light brightness	(0 ~ 100%)	8 Bit
23	0-255 RGB _ Change color	(0 = original color , 1-255 = 0 ~ 100% color change )	8 Bit
24	0-255 start display points	(0 ~ 100%)	8 Bit
25	0-255 end display point	(0 ~ 100%)	8 Bit
26	0-255 strobe _	0 = Turn off strobe 1-255 = 1 to 20 Hz	8 Bit



## DMX Charts

## 39 CHS

Channels	Value		Description	Width
1	0-255	Fixture Modes	0-239 Blackout / Safe 240-240 Setup Mode 251-251 Playback mode	8 Bit
2	0-255	Max Intensity	Defines the max intensity that can be used during playback mode (Range 0 till 100)	8 Bit
3	0-255	Test frames	Allows enabling test frames during setup mode (1 = test frame 1, 255 = test frame 255)	8 Bit
4,5	0-65535	Size X	Defines the maximum width that can be used during playback mode (Range -100 till 100%, 0 = 32768)	16 Bit
6,7	0-65535	Size Y	Defines the maximum height that can be used during playback mode (Range -100 till 100%, 0 = 32768)	16 Bit
8,9	0-65535	Position X	Defines the horizontal position that can be used during playback mode (Range -100 till 100%, 0 = 32768)	16 Bit
10,11	0-65535	Position Y	Defines the vertical position that can be used during playback mode (Range -100 till 100%, 0 = 32768)	16 Bit
12,13	0-65535	Rotation Z	Defines the rotation angle that can be used during playback mode (Range 0 till 360 degrees)	16 Bit
14	0-255	Pages	Page Index, 255 pages in total 1 = page 1, 255 = page 255	8 Bit
15	0-255	Cues	Cue Index, 255 Cues in total (1 = cue 1, 255 = cue 255)	8 Bit
16	0-255	Cue speed	Cue speed (0 = Original, 1 – 255 = 1% till 255%)	8 Bit
17	0-255	Dimmer	Defines the maximum brightness limited by setup mode (Range 0 till 100%)	8 Bit
18,19	0-65535	Zoom	Allows to zoom the cue limited by setup mode (Range 0 till 100%)	16 Bit
20,21	0-65535	X Size	Defines the maximum width limited by setup mode (Range -100 till 100%, 0 = 32768)	16 Bit
22,23	0-65535	Y Size	Defines the maximum height limited by setup mode (Range -100 till 100%, 0 = 32768)	16 Bit
24,25	0-65535	Z Angle	Defines the rotation angle limited by setup mode (Range 0 till 359 degrees)	16 Bit
26,27	0-65535	Z Rotation	Continues rotation from -60 till 60 Rpm	

28,29	0-65535	X Position	Allows for changing the horizontal position of the cue limited by setup mode (Range -100 till 100%, center = 32768)	16 Bit
30,31	0-65535	Y Position	Allows for changing the vertical position of the cue limited by setup mode (Range -100 till 100%, center = 32768)	16 Bit
32	0-255	Scan Rate	Defines the painting speed of the laser beam. (5k till original 30K)	8 Bit
33	0-255	Red	Intensity range from 0 till 100%	8 Bit
34	0-255	Green	Intensity range from 0 till 100%	8 Bit
35	0-255	Blue	Intensity range from 0 till 100%	8 Bit
36	0-255	Alpha	Allows you to shift between original cue color or RGB control. (Range, 0 = original, 1-255 = 0 till 100% alpha blending)	8 Bit
37	0-255	Points start	Allows you to remove points from the start point of a cue (Range from 100 till 0% visibility)	8 Bit
38	0-255	Points end	Allows you to remove points from the end point of a cue (Range from 1000 till 0% visibility)	8 Bit
39	0-255	Strobe	0 = Strobe disabled 1-255 = Strobe from 1 to 20 Hz	8 Bit

## DMX and ArtNet file structure

DMX and ArtNet playback both use files in the ":\DMX\" directory. The file names range from P001C001.zld to P255C255.zld. Here, "P" represents Page and "C" represents Cue.

For the 16-channel DMX command, the Page index and Cue Index correspond to P001C001.zld to P009C048.zld, supporting a total of 432 files.

For the 39-channel DMX command, the Pages and Cues correspond to P001C001.zld to P255C255.zld, supporting a total of 65,025 files.

During DMX and ArtNet playback, if the corresponding Pages and Cues files cannot be found, the laser output will be turned off.

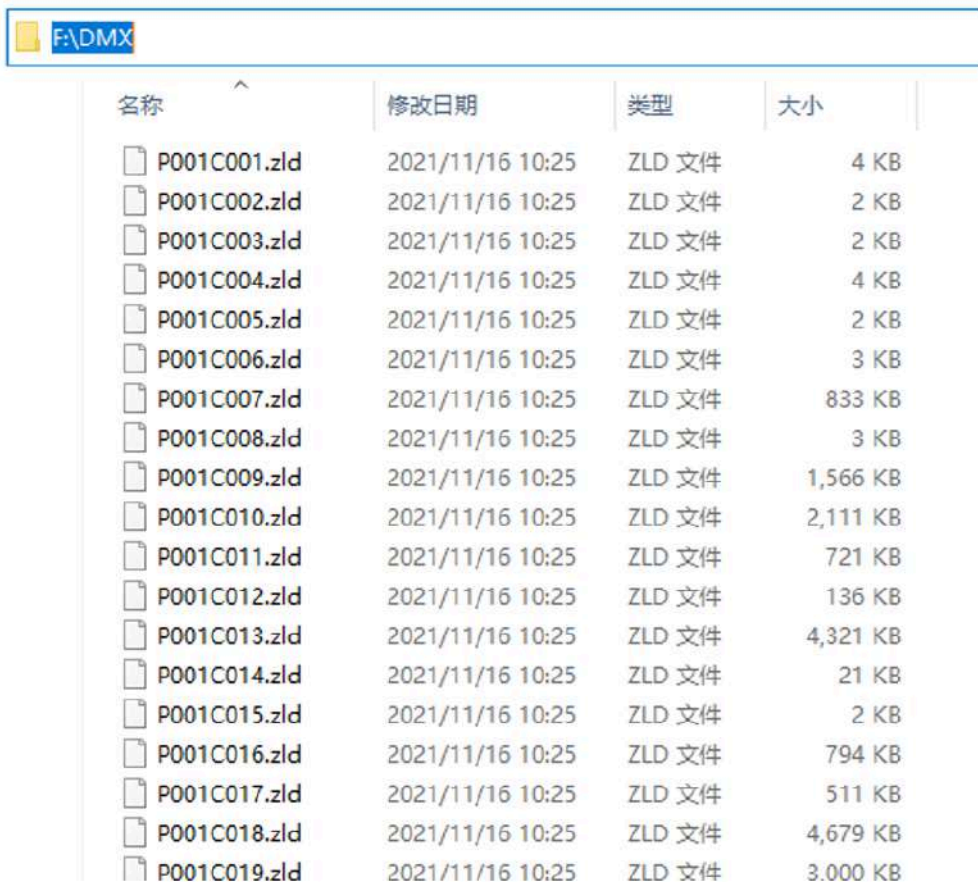

名称	修改日期	类型	大小
P001C001.zld	2021/11/16 10:25	ZLD 文件	4 KB
P001C002.zld	2021/11/16 10:25	ZLD 文件	2 KB
P001C003.zld	2021/11/16 10:25	ZLD 文件	2 KB
P001C004.zld	2021/11/16 10:25	ZLD 文件	4 KB
P001C005.zld	2021/11/16 10:25	ZLD 文件	2 KB
P001C006.zld	2021/11/16 10:25	ZLD 文件	3 KB
P001C007.zld	2021/11/16 10:25	ZLD 文件	833 KB
P001C008.zld	2021/11/16 10:25	ZLD 文件	3 KB
P001C009.zld	2021/11/16 10:25	ZLD 文件	1,566 KB
P001C010.zld	2021/11/16 10:25	ZLD 文件	2,111 KB
P001C011.zld	2021/11/16 10:25	ZLD 文件	721 KB
P001C012.zld	2021/11/16 10:25	ZLD 文件	136 KB
P001C013.zld	2021/11/16 10:25	ZLD 文件	4,321 KB
P001C014.zld	2021/11/16 10:25	ZLD 文件	21 KB
P001C015.zld	2021/11/16 10:25	ZLD 文件	2 KB
P001C016.zld	2021/11/16 10:25	ZLD 文件	794 KB
P001C017.zld	2021/11/16 10:25	ZLD 文件	511 KB
P001C018.zld	2021/11/16 10:25	ZLD 文件	4,679 KB
P001C019.zld	2021/11/16 10:25	ZLD 文件	3.000 KB

## ZLDA file structure

ZLDA playback is divided into two scenarios, one is [cue], another is [list], corresponds the files in ":\ZLDA/CUE/" and ":\ZLDA/LIST/" directory.

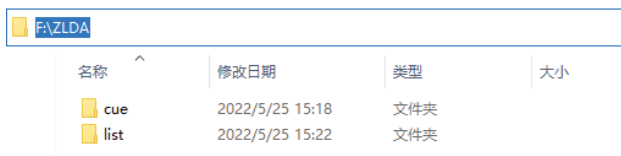

名称	修改日期	类型	大小
cue	2022/5/25 15:18	文件夹	
list	2022/5/25 15:22	文件夹	

### a. Cue mode

In the ":\ZLDA/CUE/" directory, the file names range from 001.zld to 999.zld, and the file names correspond to the menu option [File iIndex]. A total of 999 files are supported. In ZLDA cue mode playback, if the corresponding file is not found, the laser output will be turned off.

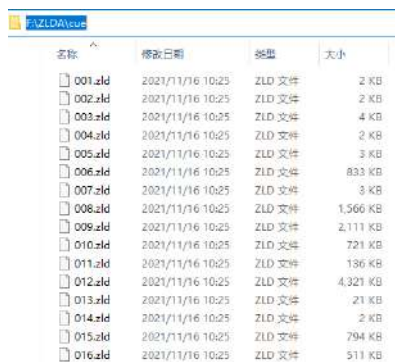

名称	修改日期	类型	大小
001.zld	2021/11/16 10:25	ZLD 文件	2 KB
002.zld	2021/11/16 10:25	ZLD 文件	2 KB
003.zld	2021/11/16 10:25	ZLD 文件	4 KB
004.zld	2021/11/16 10:25	ZLD 文件	2 KB
005.zld	2021/11/16 10:25	ZLD 文件	3 KB
006.zld	2021/11/16 10:25	ZLD 文件	833 KB
007.zld	2021/11/16 10:25	ZLD 文件	3 KB
008.zld	2021/11/16 10:25	ZLD 文件	1,566 KB
009.zld	2021/11/16 10:25	ZLD 文件	2,111 KB
010.zld	2021/11/16 10:25	ZLD 文件	721 KB
011.zld	2021/11/16 10:25	ZLD 文件	136 KB
012.zld	2021/11/16 10:25	ZLD 文件	4,321 KB
013.zld	2021/11/16 10:25	ZLD 文件	21 KB
014.zld	2021/11/16 10:25	ZLD 文件	2 KB
015.zld	2021/11/16 10:25	ZLD 文件	794 KB
016.zld	2021/11/16 10:25	ZLD 文件	511 KB

### b. List mode

In the ":\ZLDA/LIST/" directory, it is possible to create 999 directories numbered from 001 to 999. Each directory serves as a list corresponding to the file name selected in the [File Index] menu option.

In the ":\ZLDA/LIST/001/" directory, the file names range from 001.zld to 999.zld. Additionally, a play.txt file is required to indicate the playback order.



名称	修改日期	类型	大小
000.zld	2021/11/16 10:25	ZLD 文件	4 KB
001.zld	2021/11/16 10:25	ZLD 文件	2 KB
002.zld	2021/11/16 10:25	ZLD 文件	2 KB
003.zld	2021/11/16 10:25	ZLD 文件	4 KB
004.zld	2021/11/16 10:25	ZLD 文件	2 KB
005.zld	2021/11/16 10:25	ZLD 文件	3 KB
006.zld	2021/11/16 10:25	ZLD 文件	833 KB
007.zld	2021/11/16 10:25	ZLD 文件	3 KB
008.zld	2021/11/16 10:25	ZLD 文件	1,566 KB
009.zld	2021/11/16 10:25	ZLD 文件	2,111 KB
010.zld	2021/11/16 10:25	ZLD 文件	721 KB
play.txt	2022/5/25 18:35	文本文档	1 KB



## MAINTENANCE AND SERVICE

### GENERAL CLEANING INSTRUCTIONS – TO BE DONE BY USER

Due to fog residue, smoke, and dust cleaning the external body of the projector should be carried out periodically to optimize light output. Cleaning frequency depends on the environment in which the fixture operates (i.e. smoke, fog residue, dust, dew). In heavy club use we recommend cleaning on a monthly basis.

Periodic cleaning will ensure longevity, and crisp output.

- Unplug the product from power.
- Wait until the product is cold.
- Use a soft damp cloth to wipe down the outside projector casing.
- Use compressed air and a brush to wipe down the cooling vents and fan grill(s).
- Clean the glass panel (laser aperture) with glass cleaner and a soft cloth when dirty.
- Gently polish the glass surface until it is free of haze and lint.
- Always be sure to dry all parts completely before plugging the unit back in.

## Laser Colour Alignments



These procedures should be conducted only in a controlled environment and with extreme caution. When aligning the beams it is recommended to wear sufficient laser safety protection and to avoid accidental exposure to Class 4 laser radiation.

### Alignment guidelines for the PR10 projector

1. Remove the side plate on the enclosure and you will access the R/G/B dichro optic holders ① ② ③
2. Normally, we take the red beam as the reference position (means no need to adjust it) if the issue is that, the overall green or blue beam misaligned, you will need to do slight adjustments to get the involved beam back to overlay on the red beam.
3. The slight beam adjustments should be doing loosening or tightening the screws on the green laser's holder or blue laser's dichro holder.

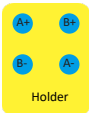

For instance, screws A+ & A- should be deemed as changing the beam's position movements from up and down; screws B+ & B- should be deemed as changing the beam's position movements from left and right. You can try to do the adjustments from the actual misaligned beam or green or blue to get the it/them back to overlay on the red beam until the white beam is achieved.

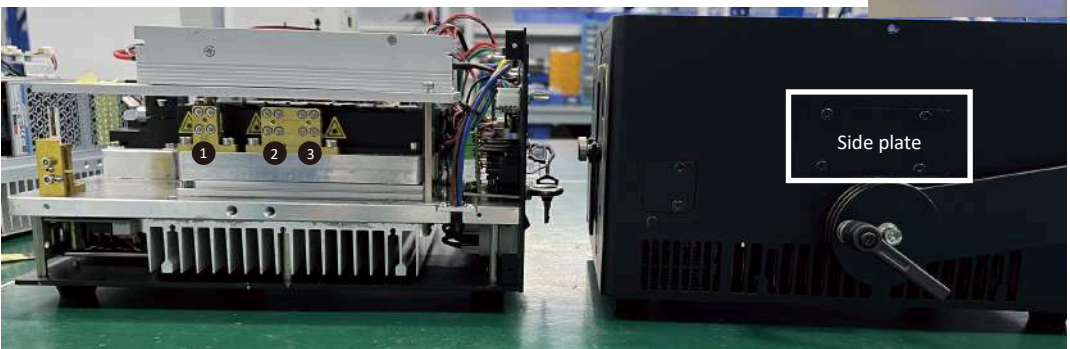

### Alignment guidelines for the CF20, CF30 and WP35 projectors

Or any Optlaser product has the same alignment window/Dichroic holders can also be referred to these step when do the work.

There is one only laser module inside this laser projector. The module contains the primary colours Red, green and blue.

The goal is to have all 3 primary colours overlay each other as perfectly as possible.

The easiest way to test and achieve alignment is to project a large circle onto a suitable surface (fire-safe surface).

It is recommended to have as much distance between the projector and the terminating wall as possible.

It is also recommended to perform the alignment using the least amount of power that enables all the laser output.

### STEP-BY-STEP INSTRUCTIONS FOR BEAM ALIGNMENT

1. Slowly and carefully remove the 6 bolts on the small side cover plate. Set the cover aside. It will not be used during this procedure.
2. Stand behind the projector and point the laser towards a large flat safe surface.



3. While standing behind the laser, power up the system as normal.
4. Project a large white circle onto a laser safe surface. Use the least amount of power that enables all the laser modules.
5. Using a hex key, reach down into the laser from above; adjust the alignment hex button screws on the combining optics until all the beams overlay each other perfectly.



Take extra care to avoid interrupting the laser beam with any tools. Class 4 laser reflections could result.



Danger – after defeating the interlock system and having the housing of the laser open, certain laser reflections happen that can cause skin burns or damage your eyes. Wear safety goggles and avoid skin exposure while adjusting the modules alignment.

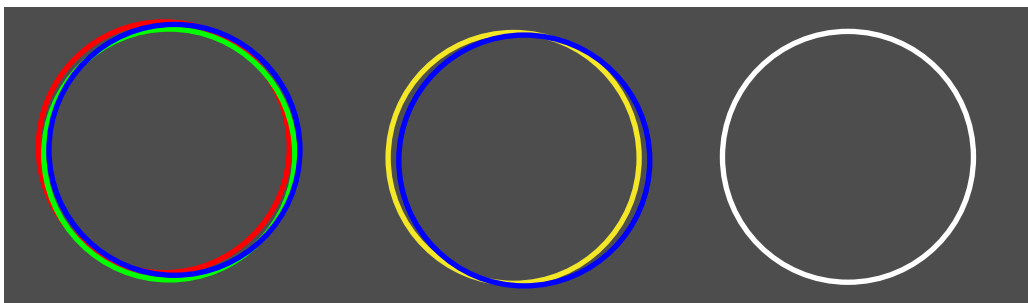

Laser module aperture

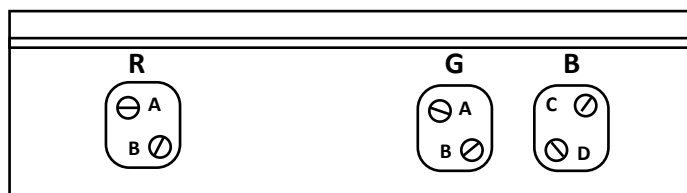

### How does the alignment mechanism work



Rotate the **A** thumb screw to tune the Red/Green's beam position from "up or down"



Rotate the **B** thumb screw to tune the Red/Green's beam position from "left or right"



Rotate the **C** thumb screw to tune the blue beam's position from "up or down"



Rotate the **D** thumb screw to tune the blue beam's position from "left or right"

**SERVICE**

There are no user serviceable parts inside this unit. Do not attempt any repairs yourself; doing so will void your manufacturer's warranty. In the unlikely event your unit may require service please contact us directly or your local distributor, who will help you with a repair or replacement. We will not accept any liability for any resulting damages caused by the non-observance of this manual or any unauthorized modification to this unit.



---

**Contact info****Shenzhen Optlaser Technologies Co., Ltd**

Add: 2F, Bldg A1, Xinjianxing Industrial Park, Xin Hu Street, Guangming Dist, Shenzhen, 518106, China.

Tel: +86(0755) 88396091

Fax: +86(755) 88396094



#### Contact

---

@moxlite.prolight  
+62 852 1567 6696  
info@moxlite.com

#### HQ & Workshop

---

Global Multipro Technology  
Rukan Crown B no. 25  
Greenlake City, Cipondoh, Tangerang